

8697 Pneumatic Control Unit/Feedback



Pneumatic control unit for decentralized automation of ELEMENT process valves

- Compact design
- Integrated pilot valve with manual override
- Internal control air routing
- Automatic end position adjustment
- With ATEX II cat. 3G/D and cat. 2D/G approval

Type 8697 can be combined with...



Type 2100

Angle seat valve



Type 2101

Globe seat valve



Type 2103

Diaphragm valve

The pneumatic control unit Type 8697 is designed for decentralized automation of process valves ELEMENT Type 21xx. Mechanical or inductive limit switches register the position of the valve. The integrated pilot valve controls single-acting actuators.

The design of the control unit and the actuator enables an internal control air routing without external tubings. Besides the electrical position feedback signal the status of the device is shown directly on the control unit itself via LEDs.

The housing is easy to clean and features proven IP protection and chemically resistant materials for use in hygienic processing, in food, beverage and pharmaceutical industries. Combined with Bürkert ELEMENT actuators the unique pilot valve system enables a compressed air recycling that avoids actuator chambers contamination from the environment.

Technical Data	
Material - Body	PPS
Material - Cover	PC
Material - Sealing	EPDM
Operating voltage *	
Pilot valve	24 V DC ±10% - residual ripple 10%, consumption 1 W
Micro switch	0-48 V AC/DC, max. 2 A 230 V Version: 50 – 250 V AC/DC, max. 2 A
Initiator	10 to 30 V DC - max. 100 mA per initiator
Control medium	neutral gases, air, quality classes acc. to ISO 8573-1
Dust concentration	Class 7: max. particle size 40 µm
Particle density	Class 5: max. particle density 10 mg/m ³
Pressure condensation point	Class 3: max. -20 °C or min. 10 °C below the lowest operating temperature
Oil concentration	Class X: max. 25 mg/m ³
Supply pressure	3 to 7 bar ¹⁾
Pilot air ports	Threaded ports G 1/8 or push-in connector (tube Ø 6 mm / 1/4")
Position feedback	2x micro switch (0 – 48 V AC/DC, max. 2 A) 2x micro switch (50 – 250 V AC/DC, max. 2 A) 2x initiator (24 V DC), PNP shutter 3-wire with LEDs 2x initiator NAMUR (8.2 V DC) (2-wire) with LEDs 2x initiator (24 V DC), shutter (2-wire) with LEDs
Stroke range valve spindle	2 to 36 mm
Ambient temperature	
with/without pilot valve	0 to +55 °C (II 3D Ex tc IIIC T135 °C Dc, II 3G Ex nA IIC T4 Gc)
with/without pilot valve with pilot valve	0 to +55 °C (II 2D Ex ia IIIC T135 °C Db IP64, II 2G Ex ia IIC T4 Gb)
with pilot valve	-10 to +55 °C (without ATEX or for II 2G Ex ia IIC T4 Gb)
without pilot valve	-20 to +60 °C (without ATEX or for II 2G Ex ia IIC T4 Gb)
Installation	as required, preferably with actuator in upright position
Protection type	IP65 / IP67 acc. to EN 60529, 4X acc. to NEMA 250 Standard
Protection class	3 acc. to DIN EN 61140
Conformity	EMC directive 2014/30/EU
Ignition protection	II 3D Ex tc IIIC T135 °C Dc II 3G Ex ec IIC T4 Gc II 2D Ex ia IIIC T135 °C Db IP64 II 2G Ex ia IIC T4 Gb

* Supply voltage according to UL NEC Class 2 for versions with cULus approval.

¹⁾ The supply pressure has to be 0.5-1 bar above the minimum required pilot pressure for the valve actuator.

Technical data, continued

Approvals	ⓈII 3D Ex tc IIIC T135 °C Dc / ⓈII 3G Ex ec IIC T4 Gc certificate; BVS 14 ATEX E 008 X ⓈII 2D Ex ia IIIC T135°C IP64 / ⓈII 2G Ex ia IIC T4 Gb certificate; BVS 13 ATEX E104 X Ex tc IIIC T135 °C Dc / Ex ec IIC T4 Gc certificate; IECEx BVS 14.0009 X Ex ia IIIC T135°C IP64 / Ex ia IIC T4 Gb certificate; IECEx BVS 13.0105X cULus certificate; E238179
ATEX	
IECEX	
UL	
Electrical connection	
Multipole	M12, 8 pin
Cable gland	M16 x 1.5 (cable Ø 4...8 mm) with terminal screws for cable cross-sections 0,14...1,5 mm ²

Ordering information for decentralized automation of On/Off ELEMENT valve systems

A decentralized, automated valve system consists of **pneumatic control unit Type 8697** and a **process valve ELEMENT Type 21xx**.

The following information is necessary for the selection of a complete system:

- **Article no.** of the desired pneumatic control unit **Type 8697** (see Ordering chart on page3)
- **Article no.** of the selected process valve **Type 21xx** (see datasheet Type 21xx)

If you order two components, you receive a complete assembled and certified valve.

When you click on the orange box "More info." below, you will come to our website for the resp. product where you can download the datasheet.

Example for decentralized automation of On/Off ELEMENT valve systems

**Pneumatic control unit
Type 8697**



Pneumatic process valves

More info.



Angle seat valve
Type 2100
(actuator Ø 50)

More info.



Globe valve
Type 2101
(actuator Ø 50)

More info.



Diaphragm valve
Type 2103
(actuator Ø 50)

On/Off ELEMENT valve system



Valve system
Type 8801-YE-U
2100+8697



Valve system
Type 8801-GC-U
2101+8697



Valve system
Type 8801-DF-U
2301+8697

Ordering chart (other versions on request)

Pneumatic control unit for decentralized automation of ELEMENT On/Off process valves Type 21xx

End position feedback												
Inductive Switch 3-wire PNP	Inductive Switch 2-wire NAMUR	Inductive Switch 2-wire 24 V DC	Micro Switch 24 V DC	Micro Switch 50-250 V AC/DC	Feedback status LEDs	Electrical connection	ATEX / IECEx Cat. 3D/G Zone 22/2 ²⁾	ATEX / IECEx Cat. 2D/G Zone 21/1 ³⁾	ATEX/ IECEx Cat. 2G Zone 1 ⁴⁾	cULus	Pilot air ports threaded ports	Article no.
Pneumatic control unit (pilot valve 3/2 way, single acting NO/NC)												
2					yes					yes	G 1/8	248816
2					yes	Cable gland	yes				G 1/8	255847
2					yes	M12 multipole	yes				G 1/8	255849
2					yes					yes	G 1/8	248818
	2				yes	Cable gland		yes			G 1/8	248822
	2				yes				yes		G 1/8	255862
		2			yes	Cable gland				yes	G 1/8	248814
		2			yes			yes			G 1/8	255845
					yes	M12 multipole				yes	G 1/8	260278
Without end position feedback							Cable gland				yes	G 1/8
					yes			yes			G 1/8	260280
Feedback (without pilot valve)												
2					yes	Cable gland				yes	G 1/8	248812
2					yes			yes			G 1/8	255843
2					yes	M12 multipole	yes				G 1/8	255857
2					yes					yes	G 1/8	250471
	2				yes	Cable gland		yes			G 1/8	248820
	2				yes				yes		G 1/8	255860
		2			yes	Cable gland				yes	G 1/8	248810
		2			yes			yes			G 1/8	255841
			2		yes	Cable gland				yes	G 1/8	248824
			2		yes					yes	G 1/8	248808

Note: cULus only valid for versions without ATEX approval

²⁾ II 3D Ex tc IIC T135 / II 3G Ex ec IIC T4 Gc

³⁾ II 2D Ex ia IIC T135 °C Db IP64 / II 2G Ex ia IIC T4 Gb

⁴⁾ II 2G Ex ia IIC T4 Gb

i Further versions on request

- > Additional**
Feedback switchpoint NPN-coded
Push-in pilot air ports (tube Ø 6 mm; 1/4")

Ordering chart adapter kit for ELEMENT (has to be ordered separately)

Description	Actuator size	Control function	Article no.
Adapter kit ELEMENT Types 21xx	Ø 50 mm	single acting / universal	682259

For installation kits to 3rd party process valves please see datasheet "Type KK01 adapter kits for hygienic process valves" or contact your sales office for related drawings or individual engineering support



**Example
ELEMENT
valve system**

Ordering chart accessories for ELEMENT

Description	Article no.
M12 socket 8 pin with 5 m cable for power supply and input / output signals	919267
Silencer G 1/8	780779
Silencer, push-in connector	902662

Materials

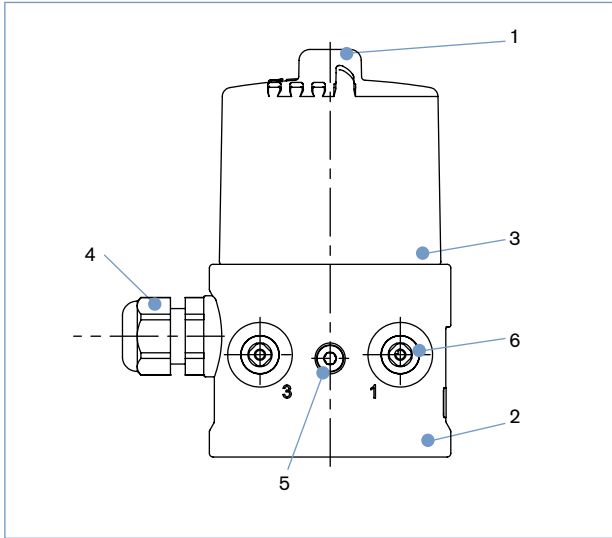

1	Transparent cap	PC
2	BASIC body	PPS
3	Sealing	EPDM
4	Cable gland	PA
	Plug M12	Brass nickel plated
5	Screws	Stainless steel
6	Push-in connector	POM / stainless steel
	Threaded ports G 1/8	stainless steel

Dimensions [mm]

Pneumatic control unit/feedback for mounting on process valve ELEMENT Types 21xx

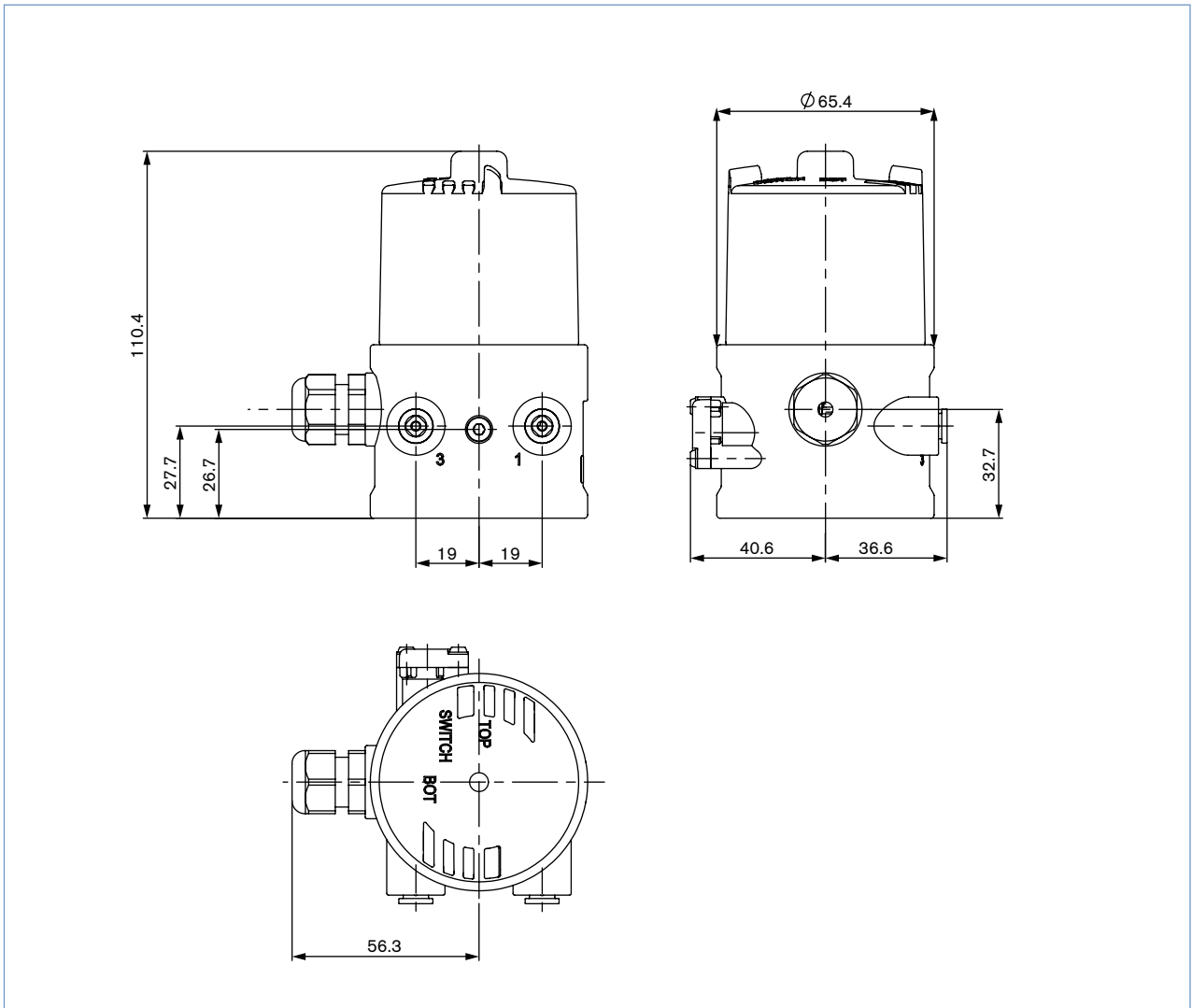

Ordering information for central automation of On/Off CLASSIC valve systems

A On/Off CLASSIC valve system consists of an **electrical position feedback Type 8697** and a **CLASSIC process valve Type 20xx**. The function of the position feedback is solely to transmit the valve end position signals to the control system. The pneumatic control of the process valve is done by the valve island in the control cabinet, either centralized or distributed depending on the system design.

The following information is necessary for the selection of a complete system:

- **Article no.** of the desired pneumatic control unit **Type 8697** (see ordering chart on p. 6)
- **Article no.** of the selected process valve **Type 20xx** (see separate datasheet Type 20xx)

You order two components and receive a complete assembled and certified valve.

Click on the orange box "More info." below... you will come to our website for the resp. product where you can download the datasheet.

Example for centralized/distributed automation of On/Off CLASSIC valve systems

The On/Off CLASSIC valve system can be combined with the **valve island Type 8640, 8644 or 8650**



More info.

**Electrical position feedback
Type 8697**



Pneumatic process valves



More info.

**Angle seat valve
Type 2000**



More info.

**Globe valve
Type 2012**



More info.

**Diaphragm valve
Type 2031**

On/Off CLASSIC valve system



**Valve system
Type 8801-YE-U
2100+8697**



**Valve system
Type 8801-GC-U
2012+8697**



**Valve system
Type 8801-GC-U
2012+8697**

Ordering chart (other versions on request)

Electrical position feedback for combination for central automation of On/Off CLASSIC valve systems Type 20xx

End position feedback						Electrical connection	ATEX / IECEx Cat. 3D/G Zone 22/2 ²⁾	ATEX / IECEx Cat. 2D/G Zone 21/1 ³⁾	ATEX / IECEx Cat. 2G Zone 1 ⁴⁾	cULus	Pilot air ports threaded ports	Article no.
Inductive switch 3-wire PNP	Inductive switch 2-wire NAMUR	Inductive switch 2-wire 24 V DC	Micro switch 24 V DC	Micro switch 50-250 V AC/DC	Feedback status LEDs							
Feedback (without pilot valve)												
2					yes	Cable gland				yes	without	248827
2					yes		yes					without
2					yes	M12 Multipole	yes				without	255858
2					yes					yes	without	250472
	2				yes	Cable gland		yes			without	248831
	2				yes				yes		without	255863
		2			yes					yes	without	248826
		2			yes		yes				without	255850
			2							yes	without	248833
				2						yes	without	248825

²⁾ II 3D Ex tc IIIC T135 / II 3G Ex nA IIC T4 Gc

³⁾ II 2D Ex ia IIIC T135 °C Db IP64 / II 2G Ex ia IIC T4 Gb

⁴⁾ II 2G Ex ia IIC T4 Gb

Ordering chart adapter kit for CLASSIC (has to be ordered separately)

Description	Actuator size	Control function	Article no.
Adapter kit CLASSIC Types 20xx	Ø 40 mm	universal	682263
	Ø 50/63/80 mm	universal	682264
	Ø 100/125 mm	universal	682265
	Ø 175/225 mm	universal	684944
Retrofit kit CLASSIC Type 20xx	Ø 40 mm	universal	698573



Example CLASSIC valve system

For installation kits to 3rd party process valves please see datasheet "Type KK01 adapter kits for hygienic process valves" or contact your sales office for related drawings or individual engineering support

* Retrofit kit for retrofitting old CLASSIC drives without clear hood on the drive cover or as a replacement for Type 1062 (phase out). Please note the general installation instructions in the manual.

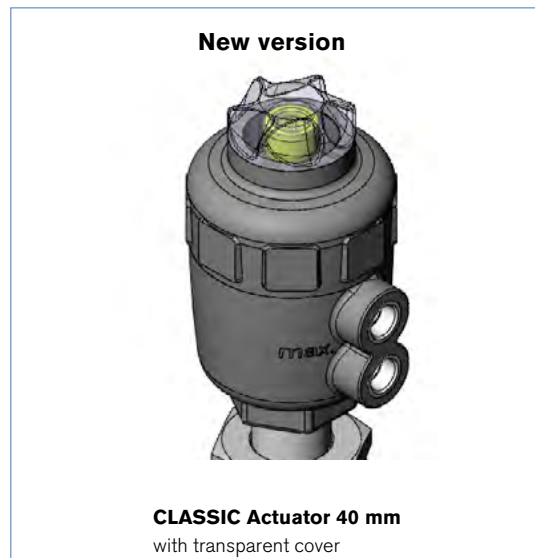

Ordering chart accessories for CLASSIC

Description	Article no.
M12 socket 8 pin with 5 m cable for power supply and input / output signals	919267
Silencer G 1/8	780779
Stroke limitation actuator CLASSIC Ø 50/63 mm	689353
Stroke limitation actuator CLASSIC Ø 80 mm	689354
Stroke limitation actuator CLASSIC Ø 100/125 mm	689355

Dimensions [mm]

Feedback for mounting on process valve CLASSIC Types 20xx

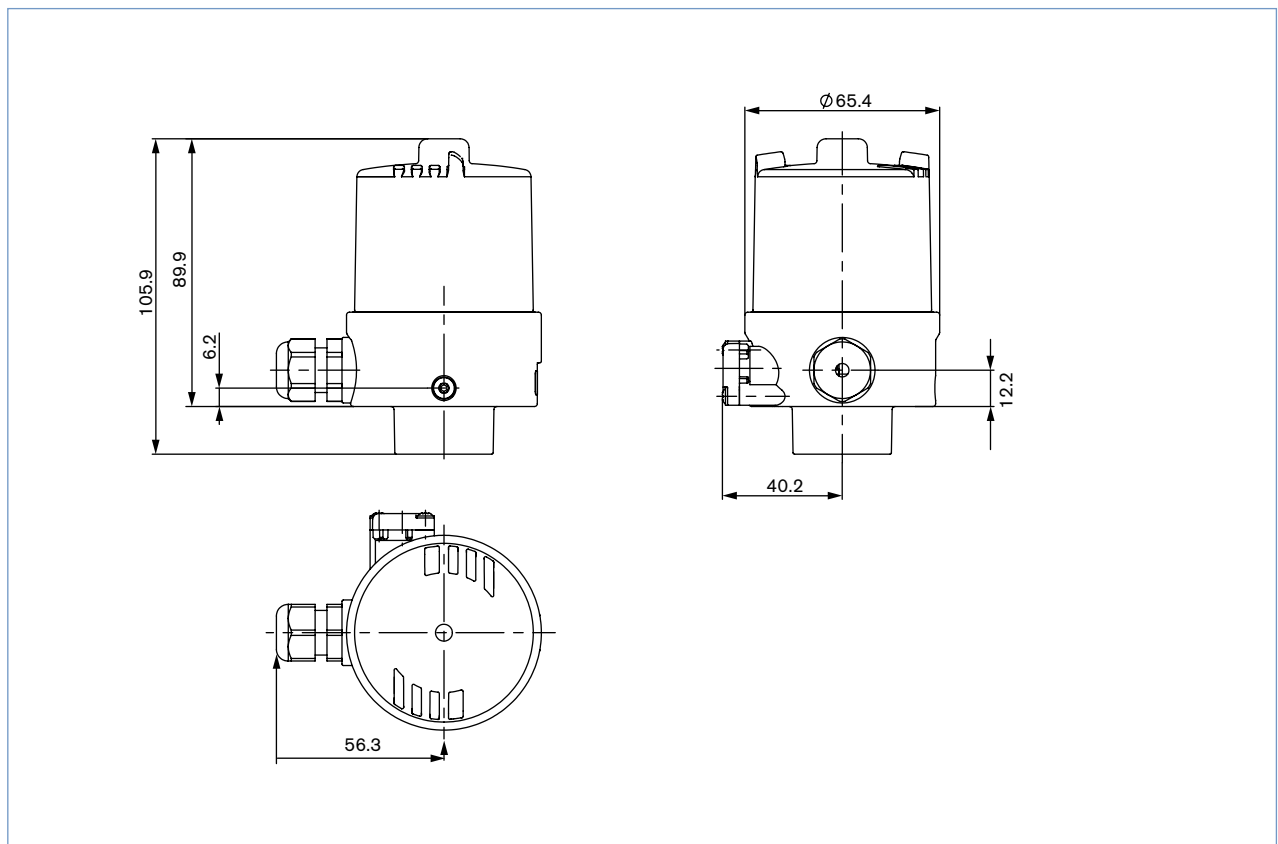

Connection options

Multipole, plug M12 8-pins

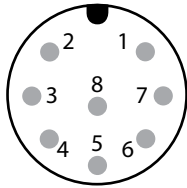

Plug configuration with 3-wire inductive switch, 24 V DC

Pin no.	Wire colour ⁹⁾	Configuration	External circuit
1	white	INI Bottom Output 1	
2	brown	INI Top Output 2	
3	green	INI - (GND) Supply	
4	yellow	INI + (24 V DC) Supply	
5	grey	Valve control 0/24 V	
6	pink	Valve control GND	

⁹⁾ The indicated colours refer to the connecting cable available as an accessory (919 061)

Cable gland , M16 × 1.5 (cable-Ø 4...8 mm), terminal screws (1.5 mm²)

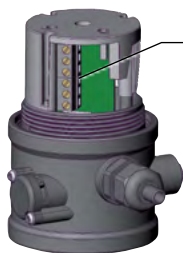

Screw terminals

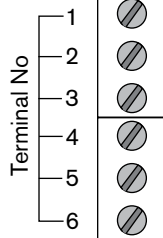

Port configuration with micro switch, 24 V DC / 250 V AC/DC

Terminal	Configuration	External circuit
1	Micro switch top	1 — NO
2		2 — NC
3		3 — Joint connection
4	Micro switch bottom	4 — NO
5		5 — NC
6		6 — Joint connection

Port configuration with 3-wire inductive switch, 24 V DC

Terminal	Configuration	External circuit
1	INI + (24 V DC) Supply	
2	INI GND Supply	
3	INI Top Output 1	
4	INI Bottom Output 2	
5	Valve control 0/24 V DC	
6	Valve control GND	

Port configuration with 2-wire inductive proximity switches



Screw terminals

2-wire inductive proximity switches (NAMUR)

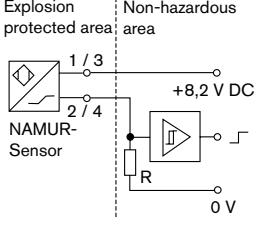
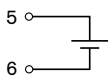
Terminal	Configuration	External circuit
1	INI Top +	
2	INI Top -	
3	INI Bottom +	
4	INI Bottom -	
5	Valve control +	
6	Valve control GND	

2-wire inductive proximity switches, 24 V

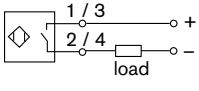
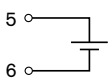
Terminal	Configuration	External circuit
1	INI Top +	
2	INI Top -	
3	INI Bottom +	
4	INI Bottom -	
5	Valve control +	
6	Valve control GND	

⁷⁾ (Acc. to NAMUR recommendation). Please note the prototype test certificate from Turck KEMA 02 ATEX 1090X

⁸⁾ Barrier signal, see PTB 07 ATEX 2048

To find your nearest Bürkert facility, click on the orange box → www.burkert.com

In case of special application conditions,
please consult for advice.

Subject to alteration.
© Christian Bürkert GmbH & Co. KG

1904/16_EU-en_00895243